

# TM-2-A5-PB0 Torque Motor

## Electrical specifications

Winding code : PB0	Symbol	Unit	Water cooling
Continuous torque	$T_c$	Nm	453
Continuous current	$I_c$	$A_{rms}$	23
Stall torque	$T_s$	Nm	371
Stall current	$I_s$	$A_{rms}$	18.4
Peak torque(for 1sec.)	$T_p$	Nm	860
Peak current(for 1sec.)	$I_p$	$A_{rms}$	52
Torque constant	$K_t$	Nm/Arms	20.78
Electrical time constant	$T_e$	ms	6.8
Resistance (line to line at 25°C)	$R_{25}$	$\Omega$	2.7
Inductance (line to line)	L	mH	18.3
Number of poles	2p		66
Back emf constant (line to line)	$K_v$	Vrms/rad/s	12
Motor constant (at 25°C)	$K_m$	Nm/ $\sqrt{W}$	10.31
Thermal resistance	$R_{th}$	K/W	0.049
Thermal sensor			PTC SNM100+SNM130+Pt1000
Max. DC BUS		$V_{DC}$	750
Inertia of rotor	J	$kgm^2$	0.108
Thermal time constant	$T_{th}$	s	120
Max. continuous power dissipation	$P_c$	W	3023
Max. peak power dissipation	$P_p$	W	15453
Rated speed(at 600VDC)		rpm	196

## Mechanical specifications

	Symbol	Unit	Water cooling
Mass of rotor	$M_r$	kg	5.5
Mass of stator	$M_s$	kg	26.8
Height of stator	$H_s$	mm	110
Height of rotor	$H_r$	mm	51
Length of rotor centring fit	H	mm	15
Water temperature difference for $P_c$	$\Delta\theta$	K	5
Minimum water flow	q	l/min	8.7
Max. pressure drop	$\Delta p$	bar	1

## T-N curve

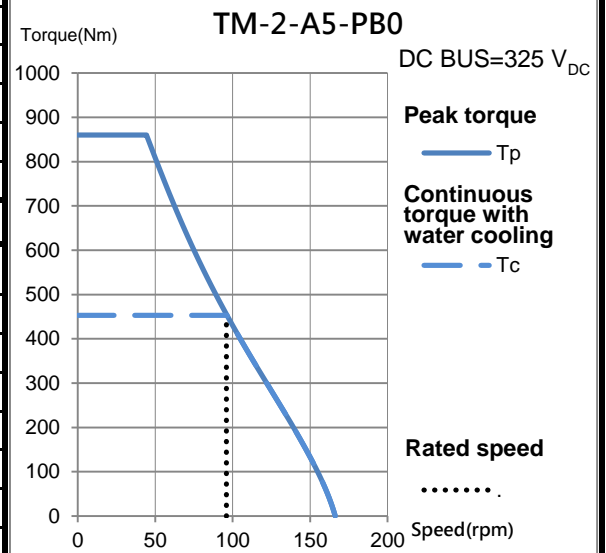
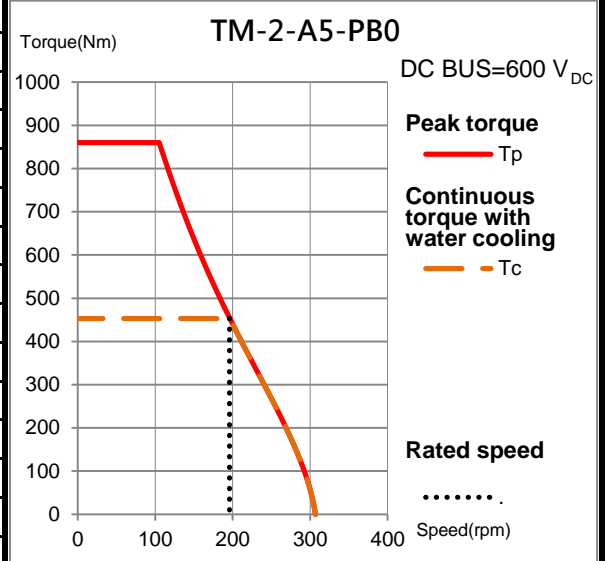

## Thermal sensor

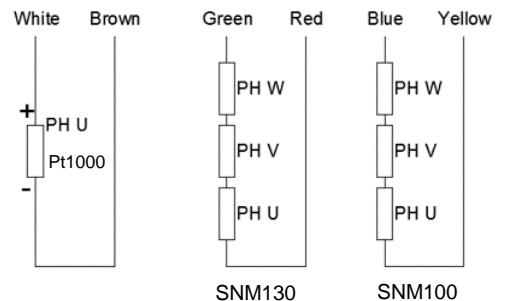
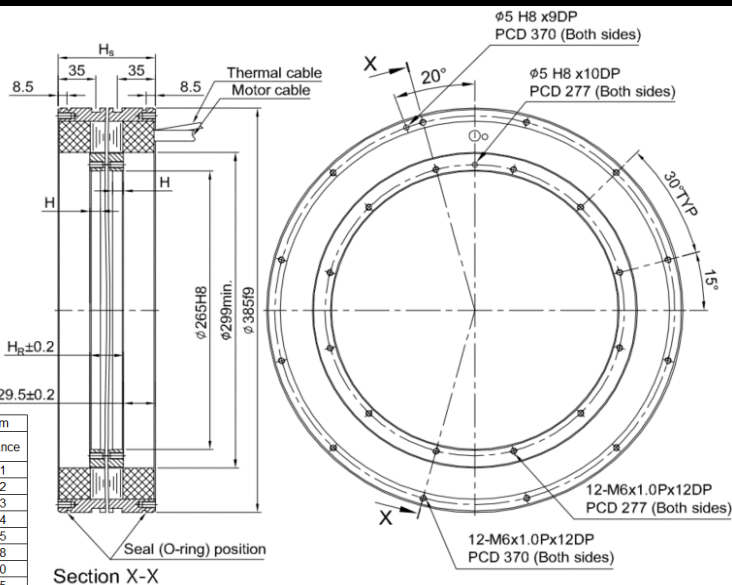

General tolerance mm	
Nominal dimension	Tolerance
> 6	±0.1
> 6 ~ 30	±0.2
> 30 ~ 120	±0.3
> 120 ~ 300	±0.4
> 300 ~ 600	±0.5
> 600 ~ 1200	±0.8
> 1200 ~ 2400	±1.0
> 2400	±1.5

Motor wire table	
Color or wire no.	Signal
U/L1	PH U
V/L2	PH V
W/L3	PH W
Green/Yellow	GND

Except dimensions, all the specifications in the table are in ±10% of tolerance

Version: 2.00

This drawing is only for reference, detail dimensions please refer to approval drawing.

Date: 2020/10/23